

Fast Recovery Diode Stud Types M0334S/RX120 to M0334S/RX180

The data sheet on the subsequent pages of this document is a scanned copy of existing data for this product.
(Rating Report 80NR15 Issue 2)

This data reflects the old part number for this product which is: **SM12-18PHN/R174**.
This part number must **NOT** be used for ordering purposes – please use the ordering particulars detailed below.

The limitations of this data are as follows:
Only S/RJ outline drawing (W24) in datasheet

The following links will direct you to the appropriate outline drawings
[Outline W22](#) – 3/4" flag top ceramic stud
[Outline W24](#) – 3/4" leaded ceramic stud

Where any information on the product matrix page differs from that in the following data, the product matrix must be considered correct

An electronic data sheet for this product is presently in preparation.

For further information on this product, please contact your local ASM or distributor.

Alternatively, please contact Westcode as detailed below.

Ordering Particulars			
M0334	S/RX	◆◆	0
Fixed Type Code	S/RC - 3/4" flag top ceramic stud S/RJ - 3/4" leaded ceramic stud	Voltage code V _{RRM} /100 12-18	Fixed Code
Typical Order Code: M0334RJ140, Reverse polarity, 3/4" leaded ceramic stud, 1400V V _{RRM}			

IXYS Semiconductor GmbH
Edisonstraße 15
D-68623 Lampertheim
Tel: +49 6206 503-0
Fax: +49 6206 503-627
E-mail: marcom@ixys.de

WESTCODE
An  IXYS Company

Westcode Semiconductors Ltd
Langley Park Way, Langley Park,
Chippenham, Wiltshire, SN15 1GE.
Tel: +44 (0)1249 444524
Fax: +44 (0)1249 659448
E-mail: WSL.sales@westcode.com

IXYS Corporation
3540 Bassett Street
Santa Clara CA 95054 USA
Tel: +1 (408) 982 0700
Fax: +1 (408) 496 0670
E-mail: sales@ixys.net

www.westcode.com

www.ixys.com

Westcode Semiconductors Inc
3270 Cherry Avenue
Long Beach CA 90807 USA
Tel: +1 (562) 595 6971
Fax: +1 (562) 595 8182
E-mail: WSI.sales@westcode.com

The information contained herein is confidential and is protected by Copyright. The information may not be used or disclosed except with the written permission of and in the manner permitted by the proprietors Westcode Semiconductors Ltd.

© Westcode Semiconductors Ltd.

In the interest of product improvement, Westcode reserves the right to change specifications at any time without prior notice.

Devices with a suffix code (2-letter, 3-letter or letter/digi/letter combination) added to their generic code are not necessarily subject to the conditions and limits contained in this report.

QUALITY EVALUATION LABORATORY

Rating Report: 80NR15 (Issue 2)

Date: 18th November, 1986

Origin:

Pages: 22

Diode Type SM12-18PHN/R174

Written by:

M.W. Dunlop

Checked:

M.W.D.

Approved:

B.R.A.

The SM12-18PHN/R diode series employs a 24 mm silicon slice mounted under spring pressure in a stud base, top hat housing with flexible lead. The report supersedes Rating Report No. 80NR15.

RATINGS AND CHARACTERISTICS

Ratings

Voltage Grades	: 12-18
V_{RSM}	: 1300-1900V
V_{RRM}	: 1200-1800V
I_F (AV); Single phase; 50 Hz, 180°C half sinewave; $T_{CASE} = 100^\circ C$: 150A
I_F (rms) max.	: 400A
I_F d.c. max.	: 400A
I_{FSM} : t = 10 ms half sinewave; T_J (initial) = 125°C ; $V_{RM} = 0.6V_{RRM}$ (MAX)	: 4500A
I_{FSM} : t = 10 ms half sinewave; T_J (initial) = 125°C ; $V_{RM} = 10V$: 4950A
I^2t : t = 10 ms; T_J (initial) = 125°C ; $V_{RM} = 0.6V_{RRM}$ (MAX)	: $101 \times 10^3 A^2S$
I^2t : t = 10 ms; T_J (initial) = 125°C ; $V_{RM} \leq 10V$: $122 \times 10^3 A^2S$
I^2t : t = 3 ms; T_J (initial) = 125°C ; $V_{RM} \leq 10V$: $91 \times 10^3 A^2S$
T_C Operating Range	: -40 to 125°C
T_{stg} Non-operating	: -40 to 150°C

Characteristics

(maximum values unless otherwise stated)

$V_0; T_J = 125^\circ\text{C}$:	1.00V
$r_f; T_J = 125^\circ\text{C}$:	0.74mohms
$V_{FM}; I_{FM} = 470\text{A} \quad T_{VJ} = 125^\circ\text{C}$:	1.35V
$R_{th(J-C)}$:	0.13°C/W
$R_{th(C-HS)}$:	0.04°C/W
$I_{RRM}; T_J = 125^\circ\text{C}; V_{RM} = V_{RRM}(\text{Max})$:	20mA
$Q_{rr} (I_{FM} = 550\text{A}; dI/dt = 40\text{A}/\mu\text{s})$:	160uC
$t_{rr} (V_{RM} = 50\text{V}; T_{VJ} = 125^\circ\text{C})$:	
Mounting torque	:	2.5 - 2.77 Kg.f.m.
Outline drawing	:	100A280
JEDEC Outline No.	:	

CONTENTS

	<u>Page</u>
Ratings and characteristics	1, 2
Voltage grade table	4
2. <u>Introduction</u>	5
3. <u>Notes on the Ratings</u>	
(a) Square wave ratings	5
(b) Energy per pulse characteristics	5
(c) Housing Loss	5
4. <u>Reverse Recovery Loss</u>	
(a) Determination by Measurement	5
(b) Design Method	6
Limit Forward Characteristic	7
Transient Thermal Impedance	8
Surge Rating	9
Recovered Charge	10
5. Factor	11
Reverse recovery energy per pulse	12
Square wave frequency rating 90°C Case 200A/uS	13
Square wave frequency rating 60°C Case 200A/uS	14
Square wave frequency rating 90°C Case 100A/uS	15
Square wave frequency rating 60°C Case 100A/uS	16
Energy per pulse 200A/uS	17
Energy per pulse 100A/uS	18
Sine wave frequency rating 90°C Case	19
Sine wave frequency rating 60°C Case	20
Sine wave energy per pulse	21
Outline drawing	22
80NR15 (issue 1) changes:	
P1, 4	Max grade changed
	V_{RWM} omitted
	T_B (operating range) MIN changed
Old pp 5,6,7,8	replaced
Old p9	Curves redrawn on separate sheets
Old p11	Omitted
Old p12	redrawn
Old p13	redrawn
Old p14	redrawn
Old p15	omitted
Old p20, 21	omitted
Old p26	omitted
Old pp16-27	redrawn

Voltage Ratings

Voltage Class	V_{RRM} V	V_{RSM} V
12	1200	1300
14	1400	1500
16	1600	1700
18	1800	1900

This Report is applicable to higher or lower voltage grades when supply has been agreed by Sales/Production.

2.0 Introduction

The diode series comprises fast recovery stud based devices with all diffused silicon slices. All these diodes have controlled reverse recovery characteristics with good "S" factors.

3.0 Notes on the Ratings

(a) Square wave ratings

These ratings are given for leading edge linear rates of rise of forward current of 200 and 100A/uS.

(b) Energy per pulse characteristics

These curves enable rapid estimation of device dissipation to be obtained for conditions not covered by the frequency ratings.

Let: E_p be the Energy per pulse for a given current and pulse width in joules, and f be the repetition rate

$$\text{Then } W_{AV} = E_p \times f$$

$$T_{CASE} = 125 - E_p \times f \times R_{th}$$

(c) Housing Loss

The loss caused by coupling between housing and anode current (which gives rise to additional heating at high frequency) has been incorporated into the curves of forward energy loss per pulse.

4.0 Reverse Recovery Loss

On account of the number of circuit variables affecting reverse recovery voltage, no allowance for reverse recovery loss has been made in these ratings. The following procedure is recommended for use where it is necessary to include reverse recovery loss.

(a) Determination by Measurement

From waveforms of recovery current obtained from a high frequency shunt (see Note 1) and reverse voltage present during recovery, an instantaneous reverse recovery loss waveform must be constructed. Let the area under this waveform be A joules per pulse. A new case temperature can then be evaluated from:

$$T_{CASE}(\text{new}) = T_{CASE}(\text{original}) - A \left(\frac{r_t \cdot 10^6}{t} + R_{th} \times f \right)$$

$$\text{where } r_t = 1.64 \times 10^{-4} \sqrt{t}$$

t = duration of reverse recovery loss per pulse in microseconds

A = Area under reverse loss waveform per pulse in joules (W.S.)

f = rated frequency at the original case temperature

The total dissipation is now given by

$$W(\text{TOT}) = W(\text{original}) + A \times f$$

Note 1

Reverse Recovery Loss by Measurement

This device has a low reverse recovered charge and peak reverse recovery current. When measuring the charge care must be taken to ensure that:

- (a) a.c. coupled devices such as current transformers are not affected by prior passage of high amplitude forward current.
- (b) The measuring oscilloscope has adequate dynamic range - typically 100 screen heights - to cope with the initial forward current without overload.
- (c) Measurement of reverse recovery voltage waveform should be carried out with an appropriate snubber of 0.1uF, 5 ohms connected across diode anode to cathode.

(b) Design Method

In circumstances where it is not possible to measure voltage and current conditions, or for design purposes, the additional losses may be estimated from curves on page 12.

Let E be the value of energy per reverse cycle in joules (curves on page 12).

Let f be the operating frequency in Hz

$$\text{Then } T_{\text{CASE new}} = T_{\text{CASE original}} - ER_{\text{th}} \times f$$

Where $T_{\text{CASE new}}$ is the required maximum case temperature and $T_{\text{CASE original}}$ is the case temperature given with the frequency ratings.

FORWARD CHARACTERISTIC OF LIMIT DEVICE

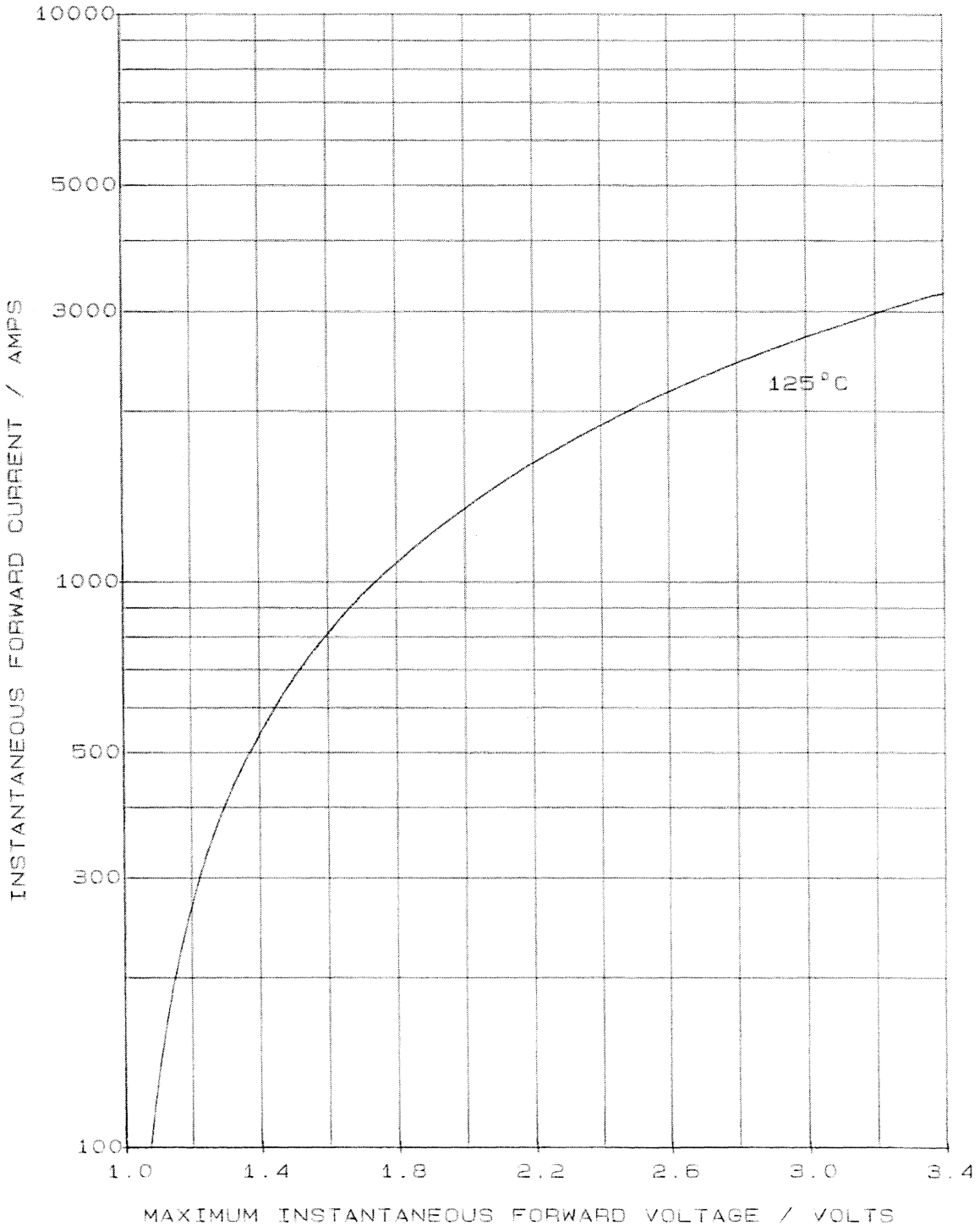

JUNCTION TO CASE THERMAL IMPEDANCE

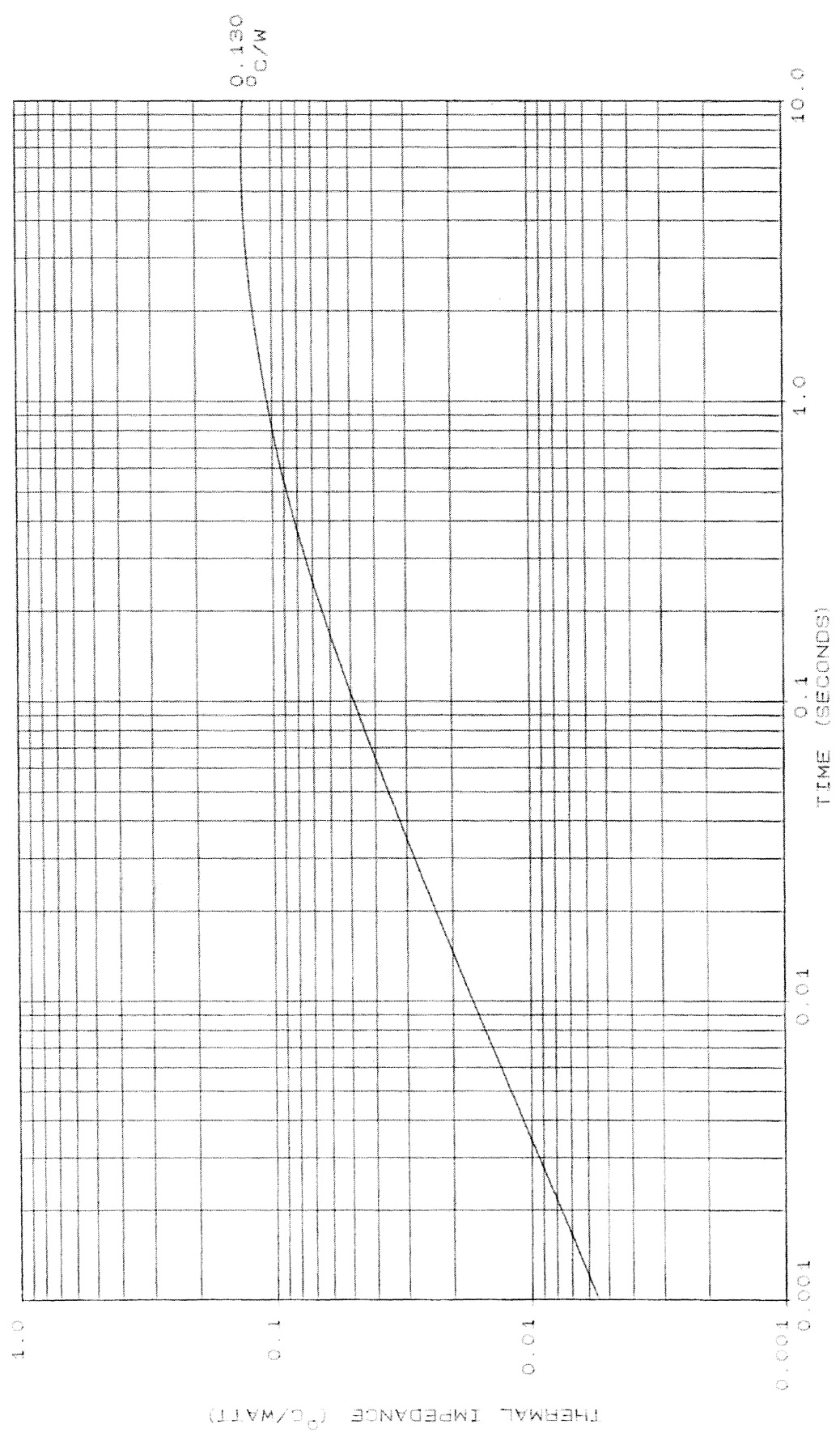

MAXIMUM NON REPETITIVE SURGE CURRENT AT INITIAL JUNCTION TEMPERATURE 125°C

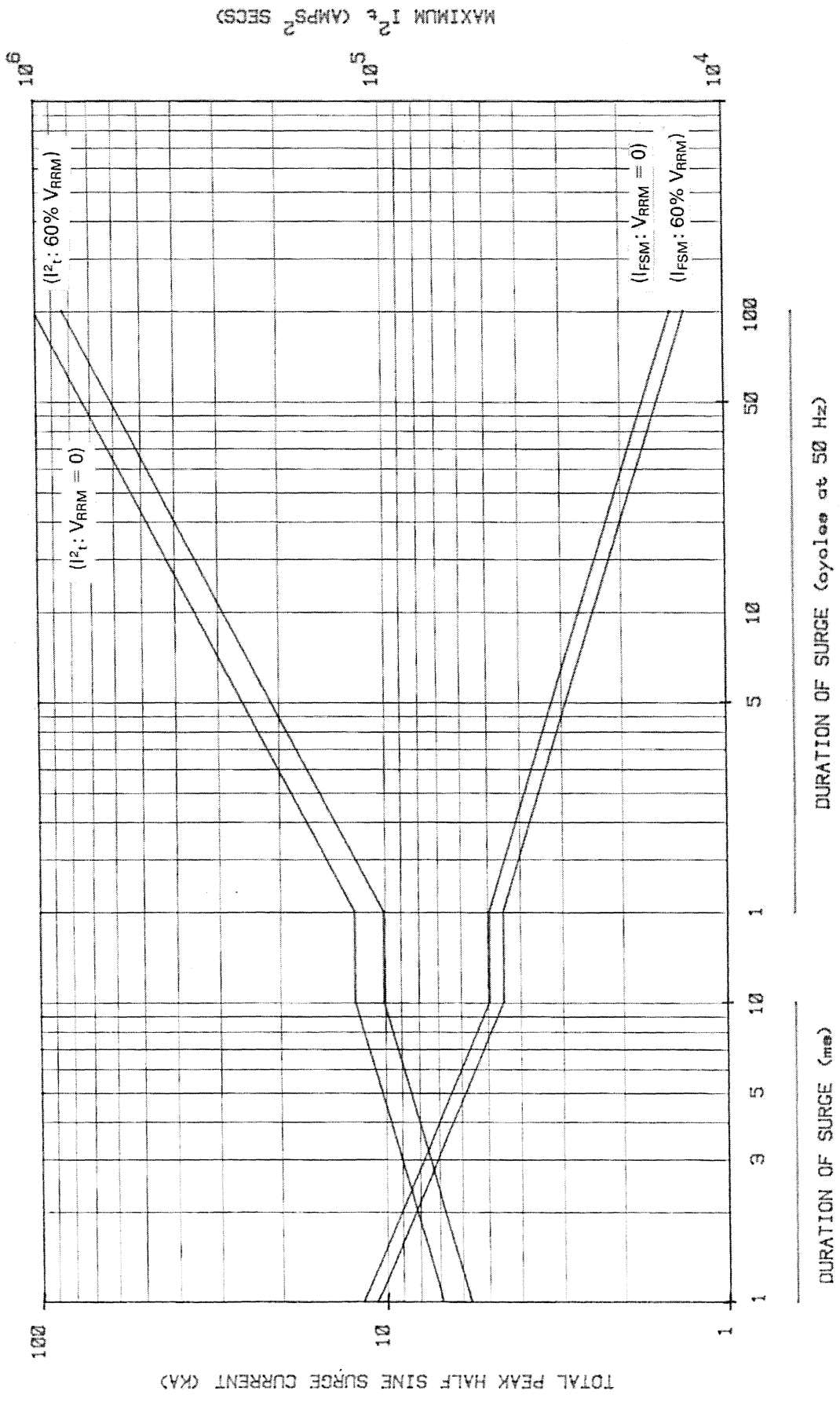

MAXIMUM RECOVERED CHARGE AT 125°C JUNCTION TEMPERATURE

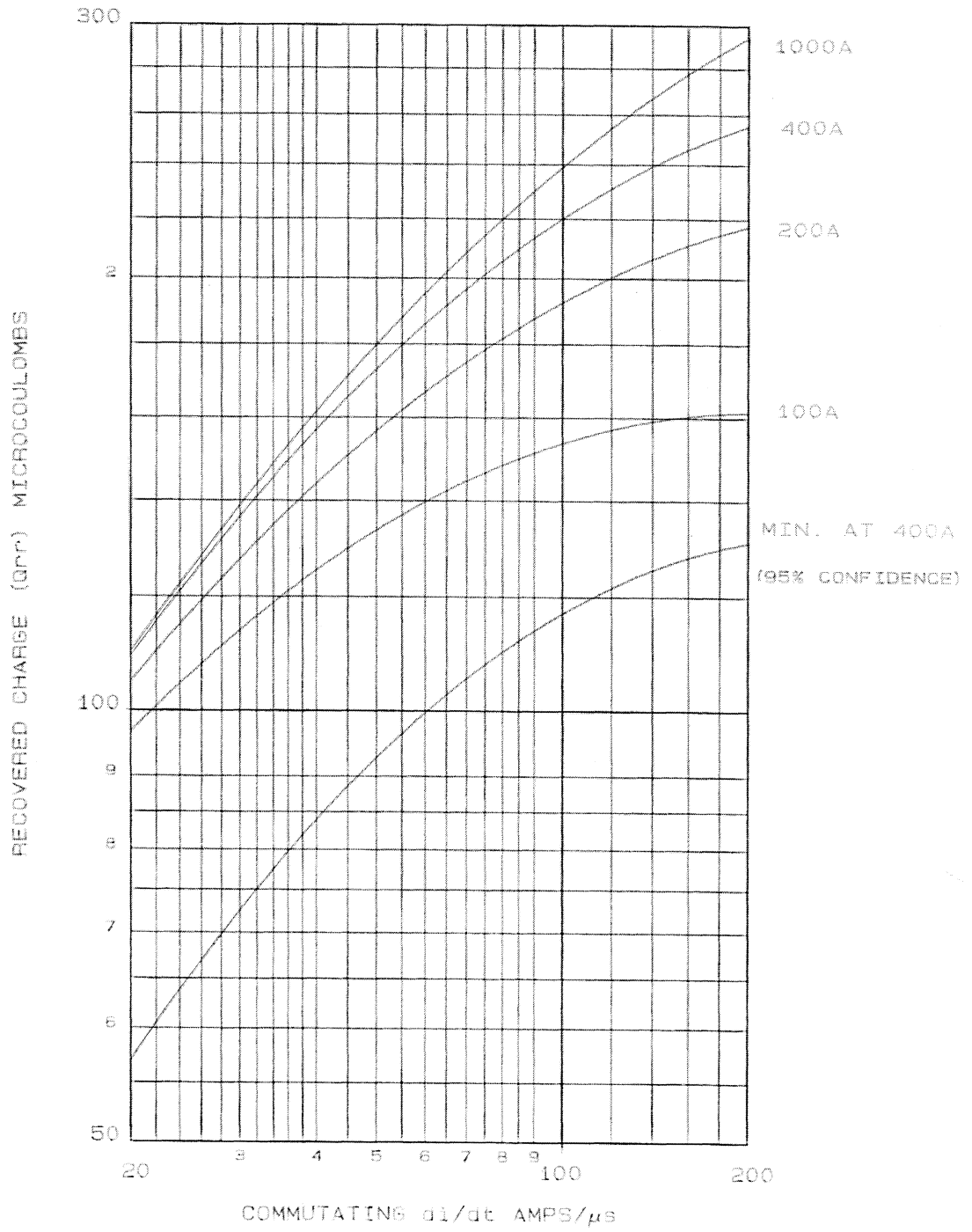

MINIMUM S FACTOR AT 125°C JUNCTION TEMPERATURE

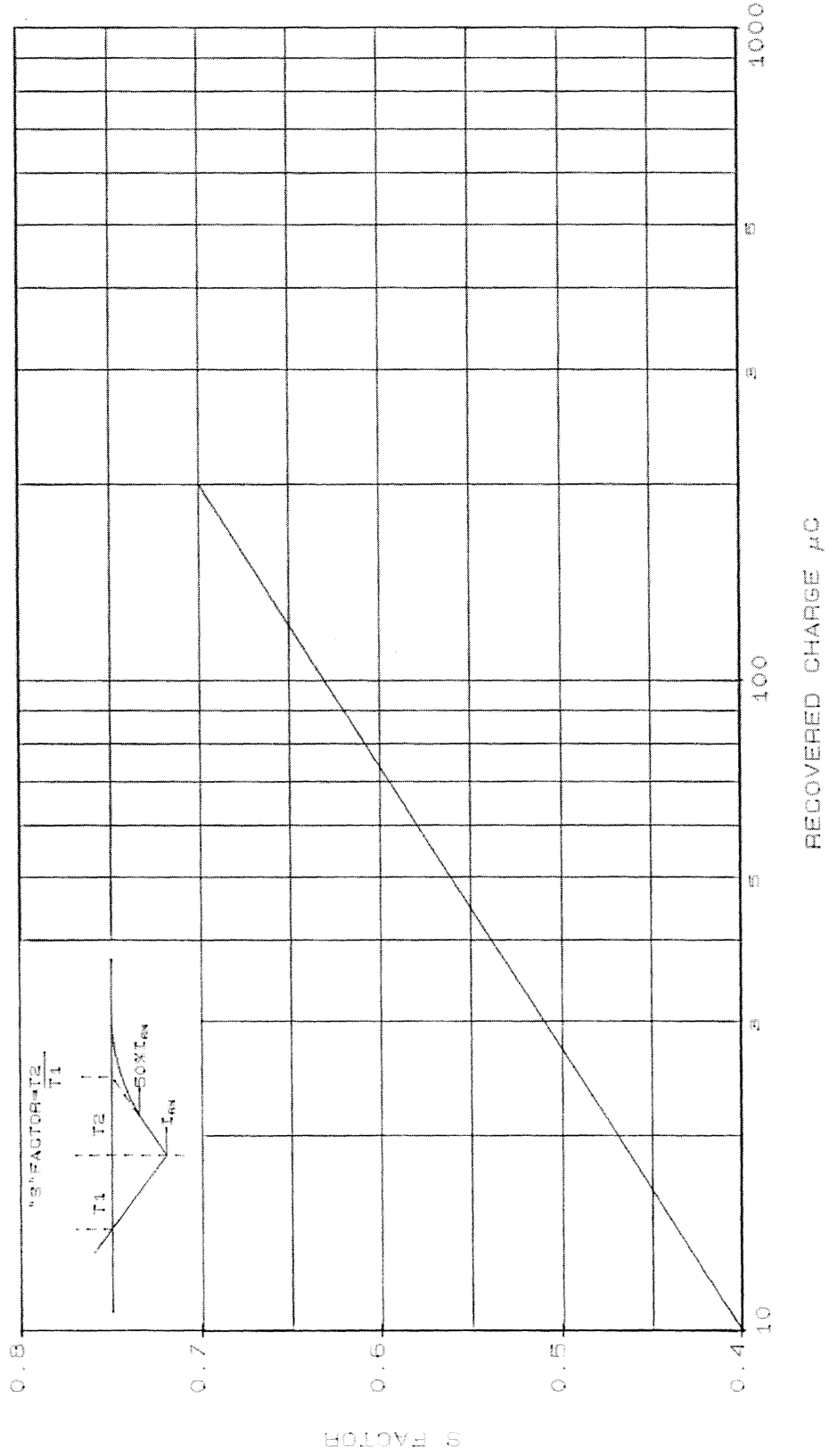

MAXIMUM REVERSE RECOVERY ENERGY LOSS PER PULSE, 125°C JUNCTION TEMPERATURE

SNUBBER CONNECTED 0.10μF, 5 OHMS
 PEAK REVERSE VOLTAGE VRM = 0.67 OF HIGHEST GRADE VOLTAGE*

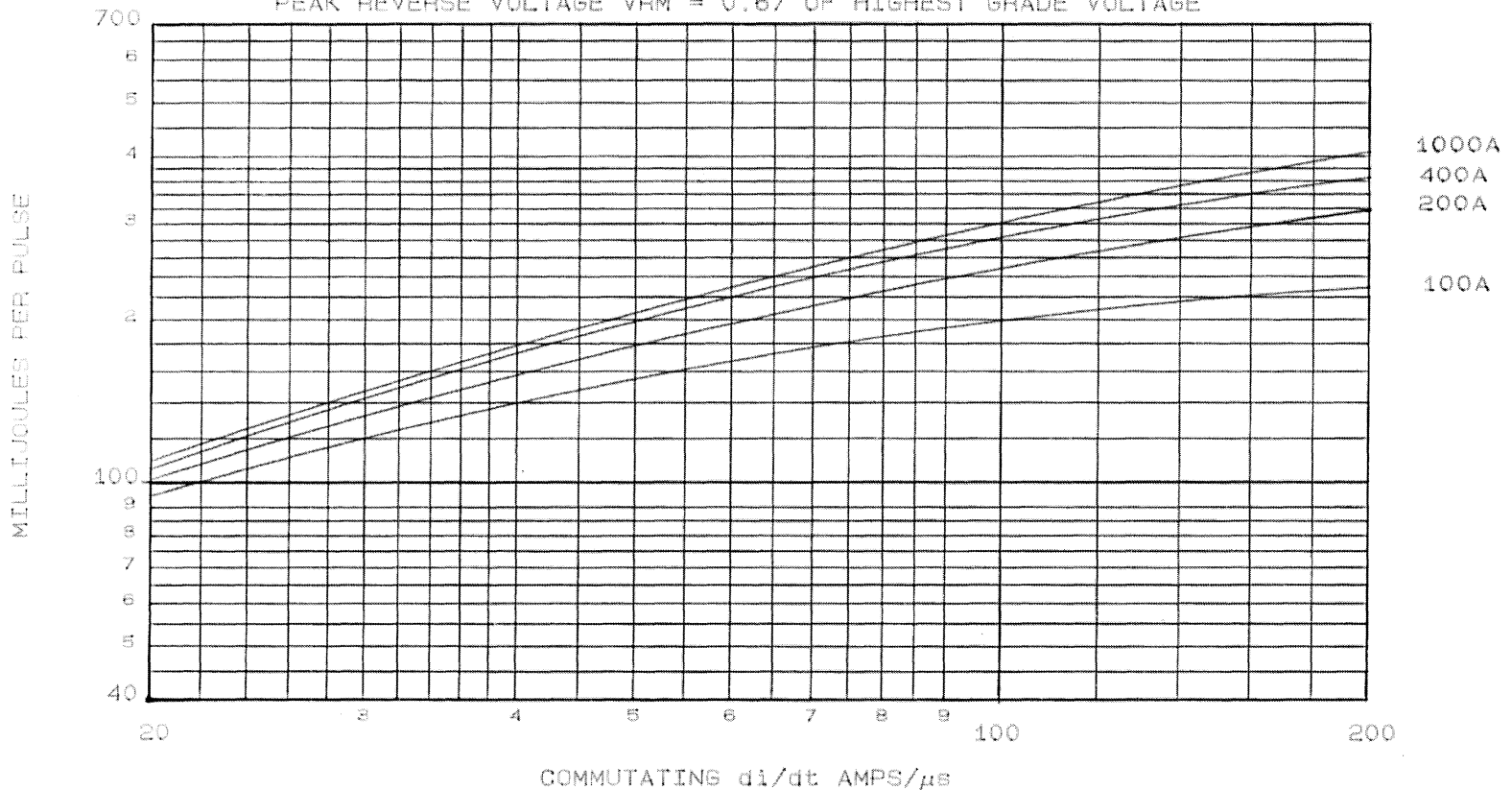

* NOTE: ENERGY PER PULSE SHOULD BE ADJUSTED PRO RATA WITH APPLIED PEAK RECOVERY VOLTAGE

Γ CASE 90degC, 200A/μs

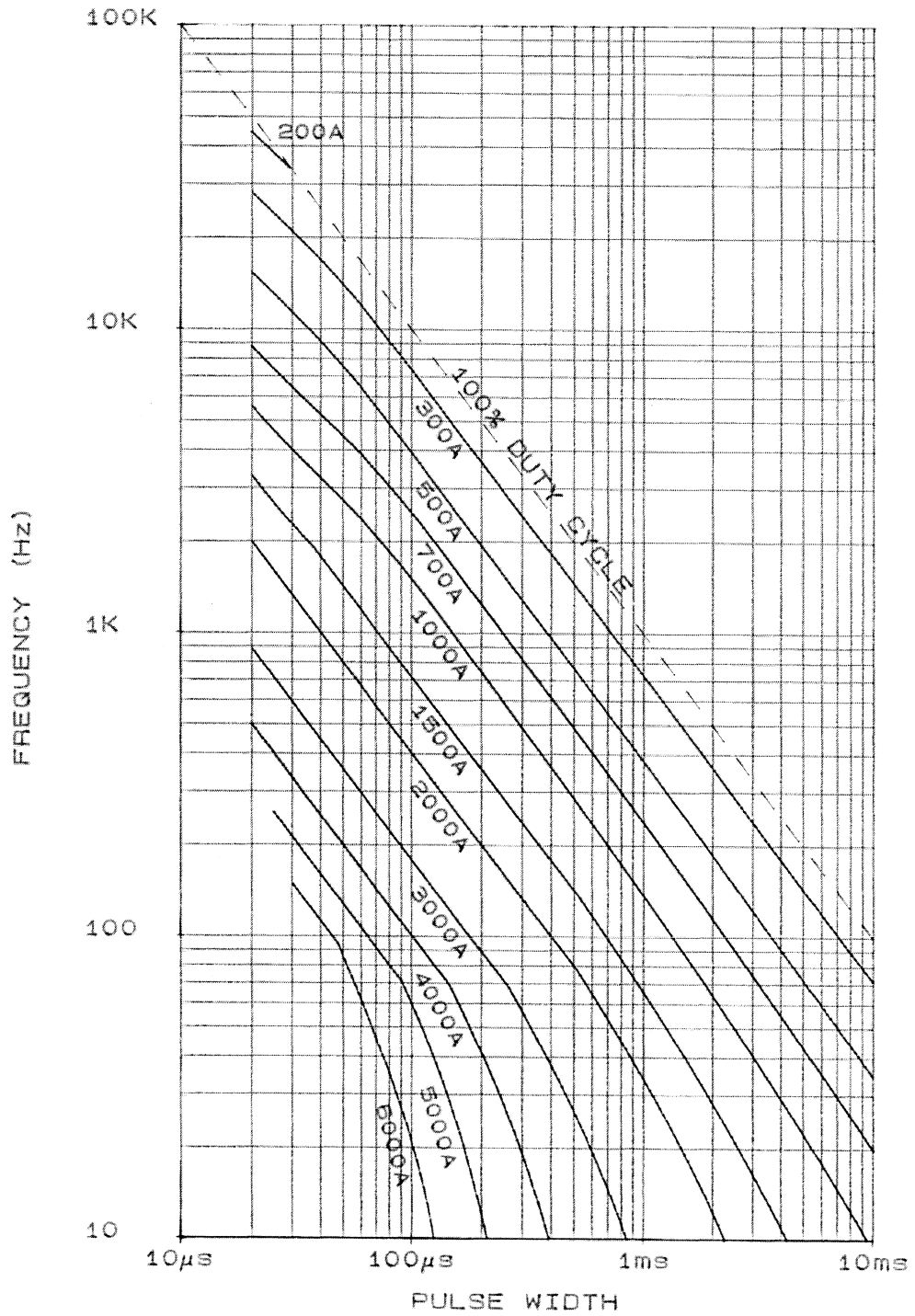

T CASE 60degC, 200A/ μ s

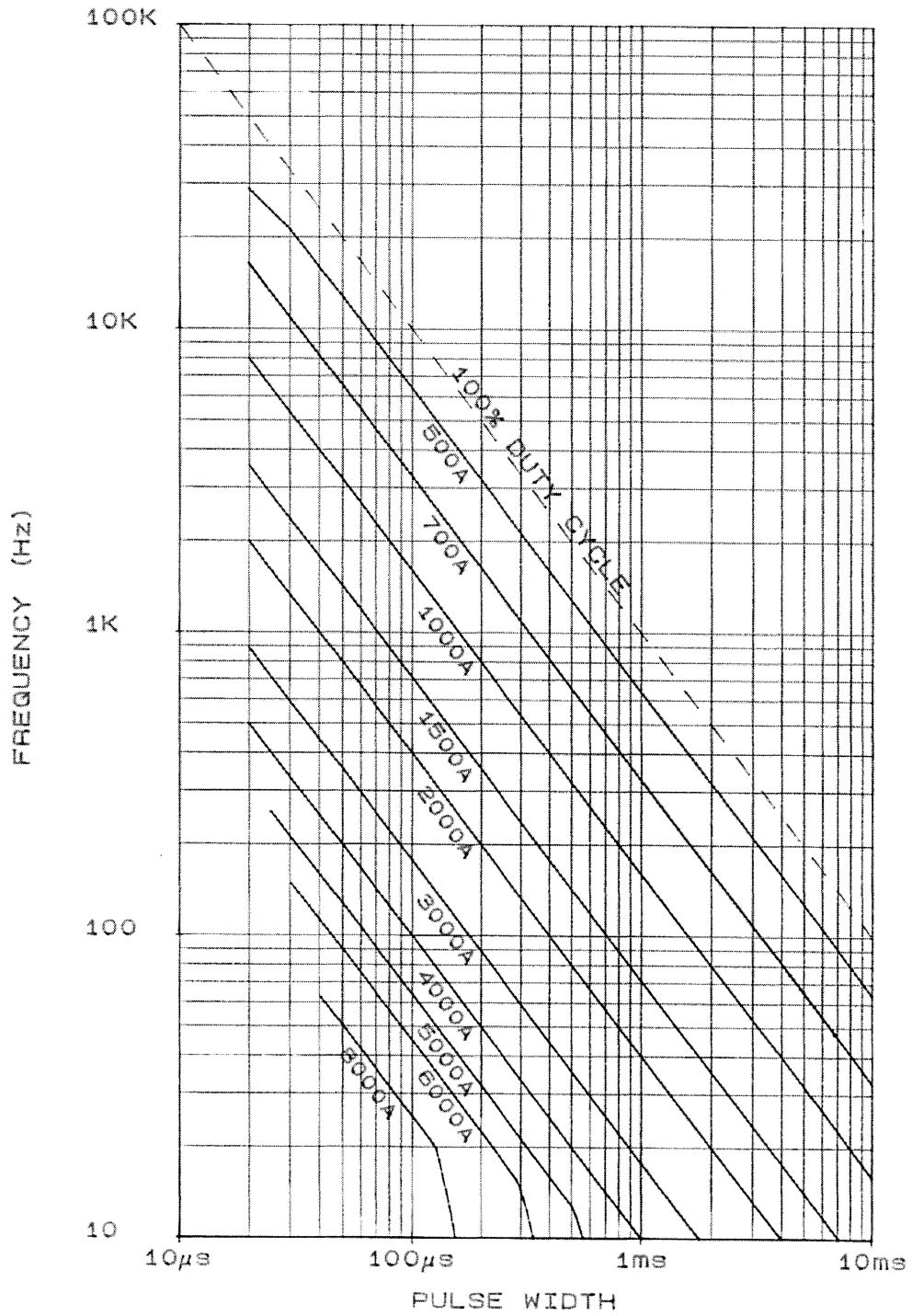

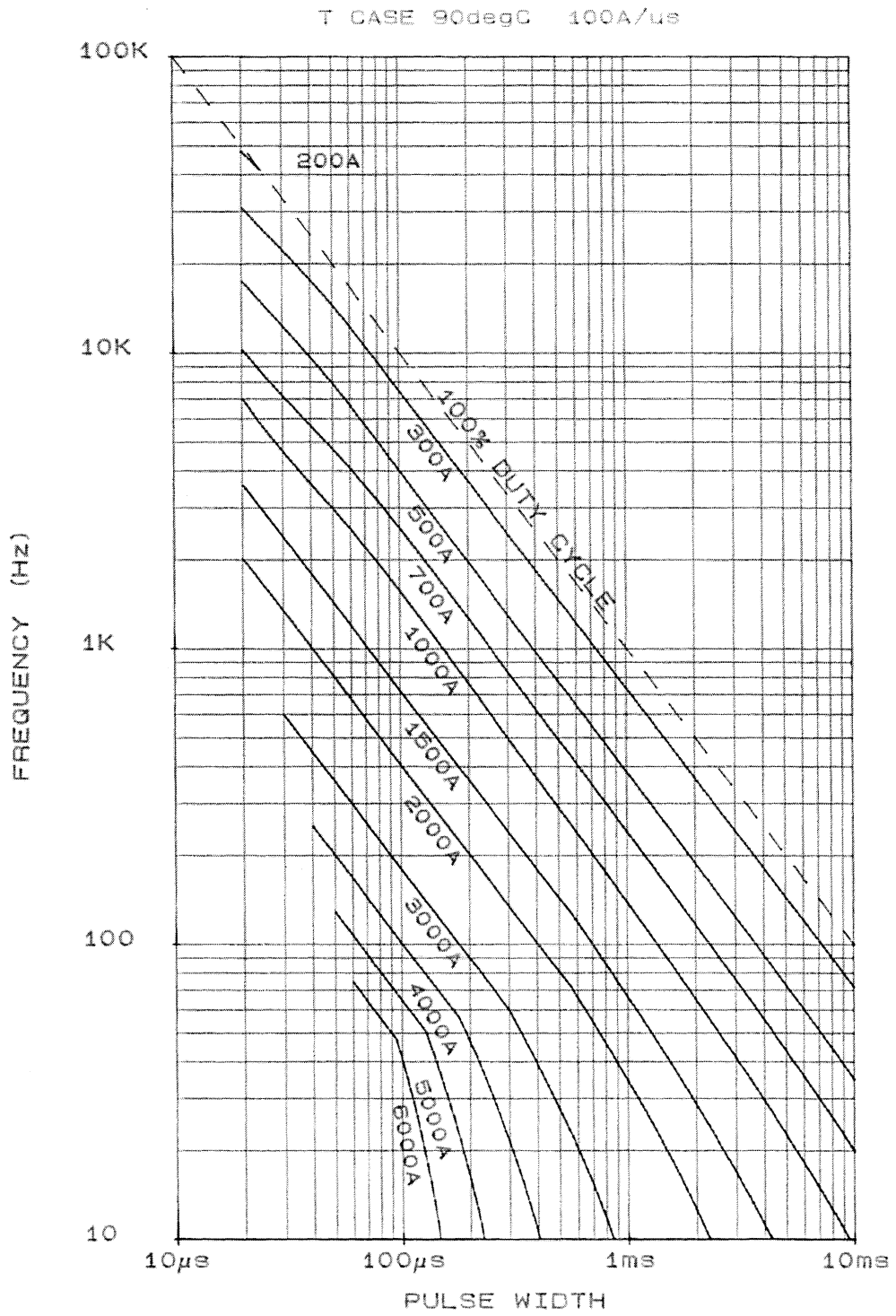

T CASE 60degC, 100A/ μ s

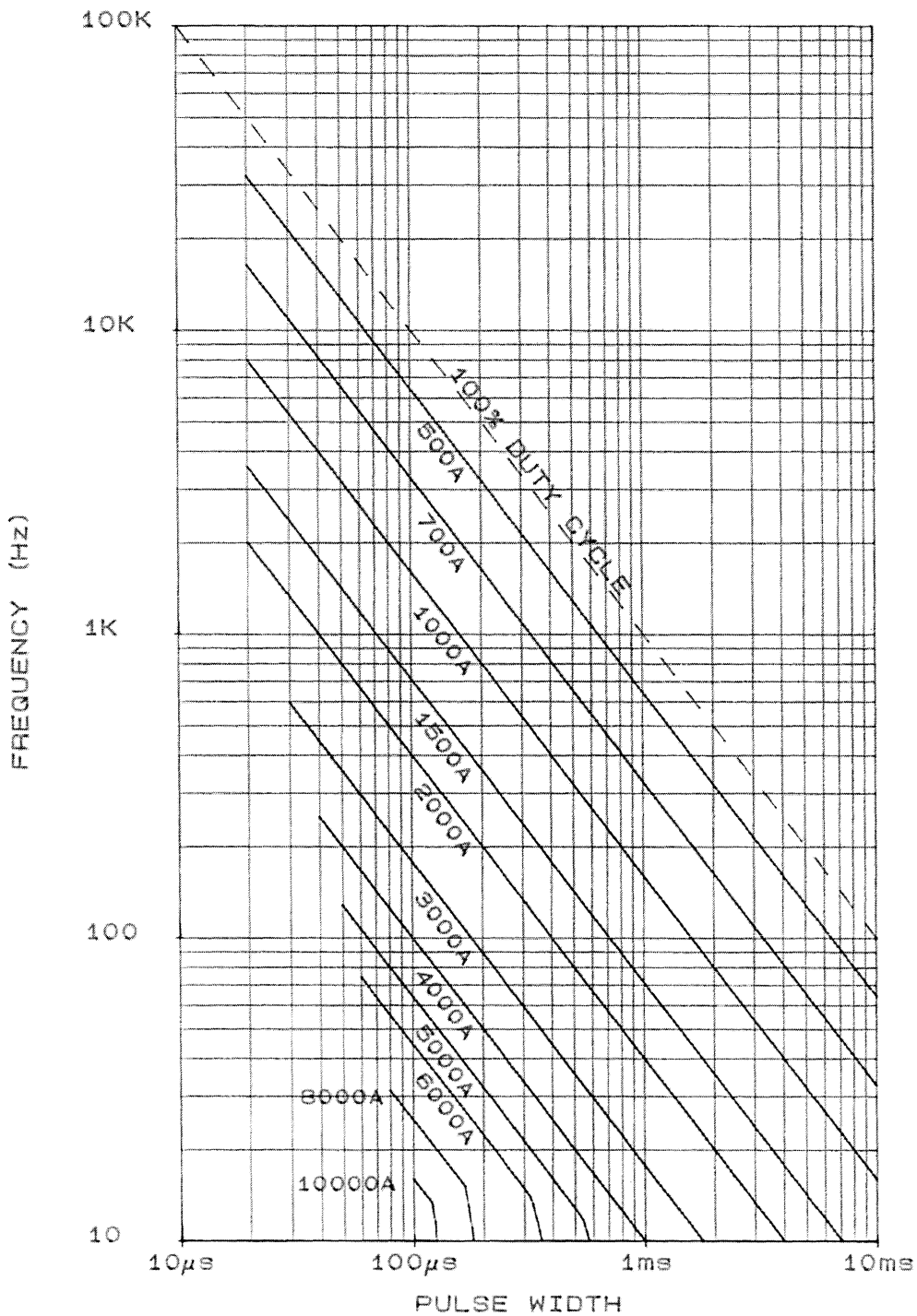

T_j 125°C. 200A/μs

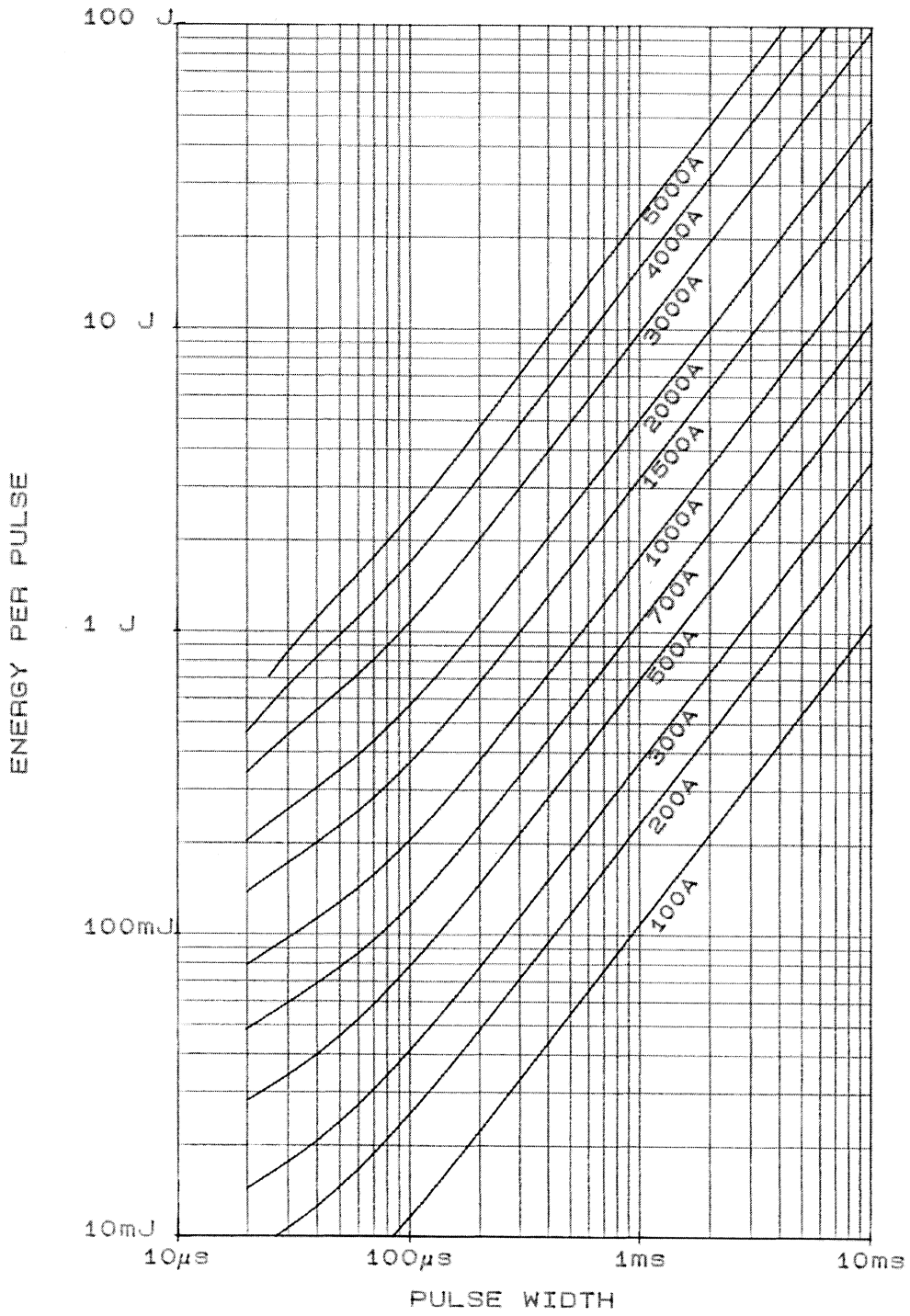

Tj 125°C. 100A/μs

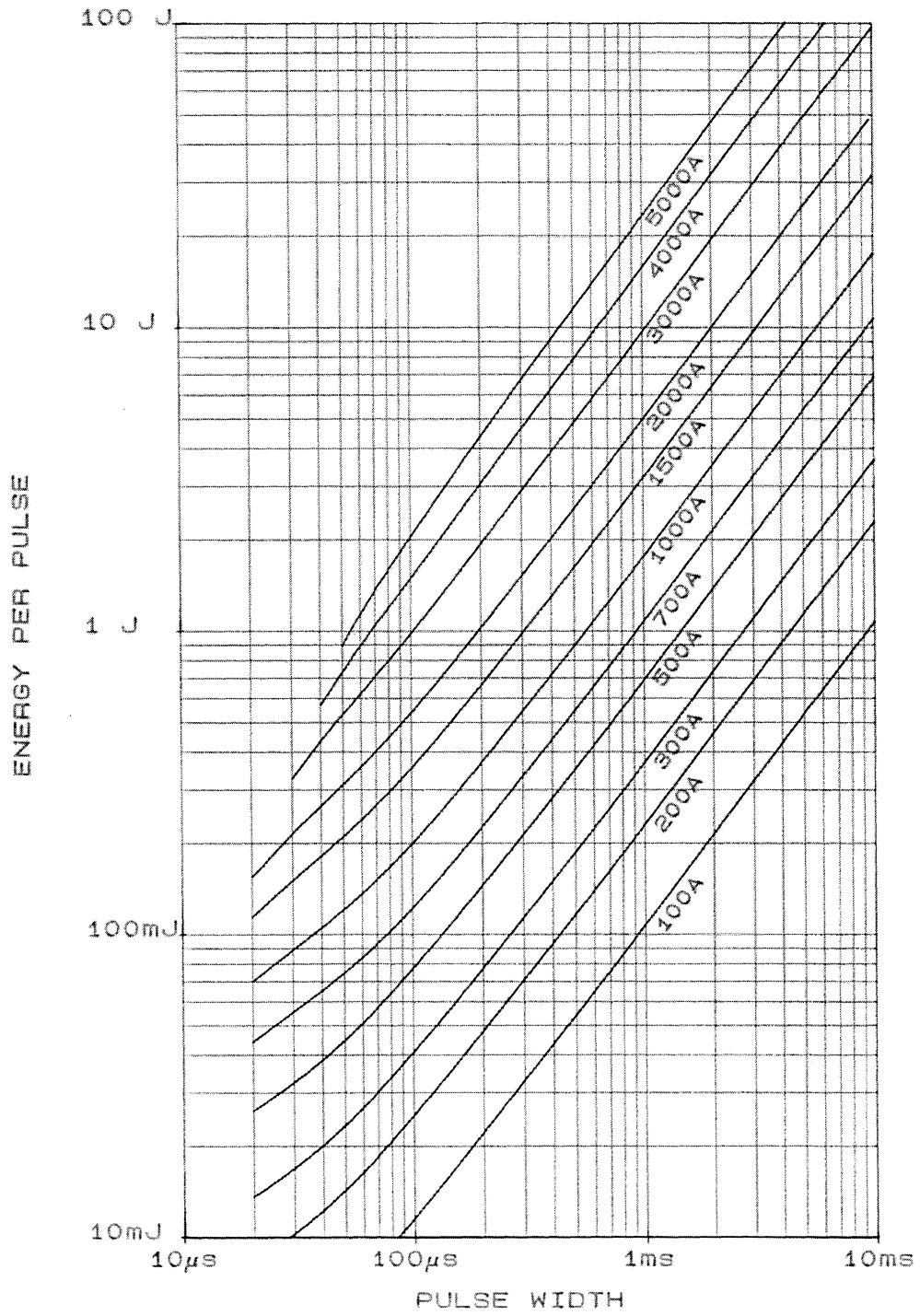

T CASE 90degC, SINEWAVE

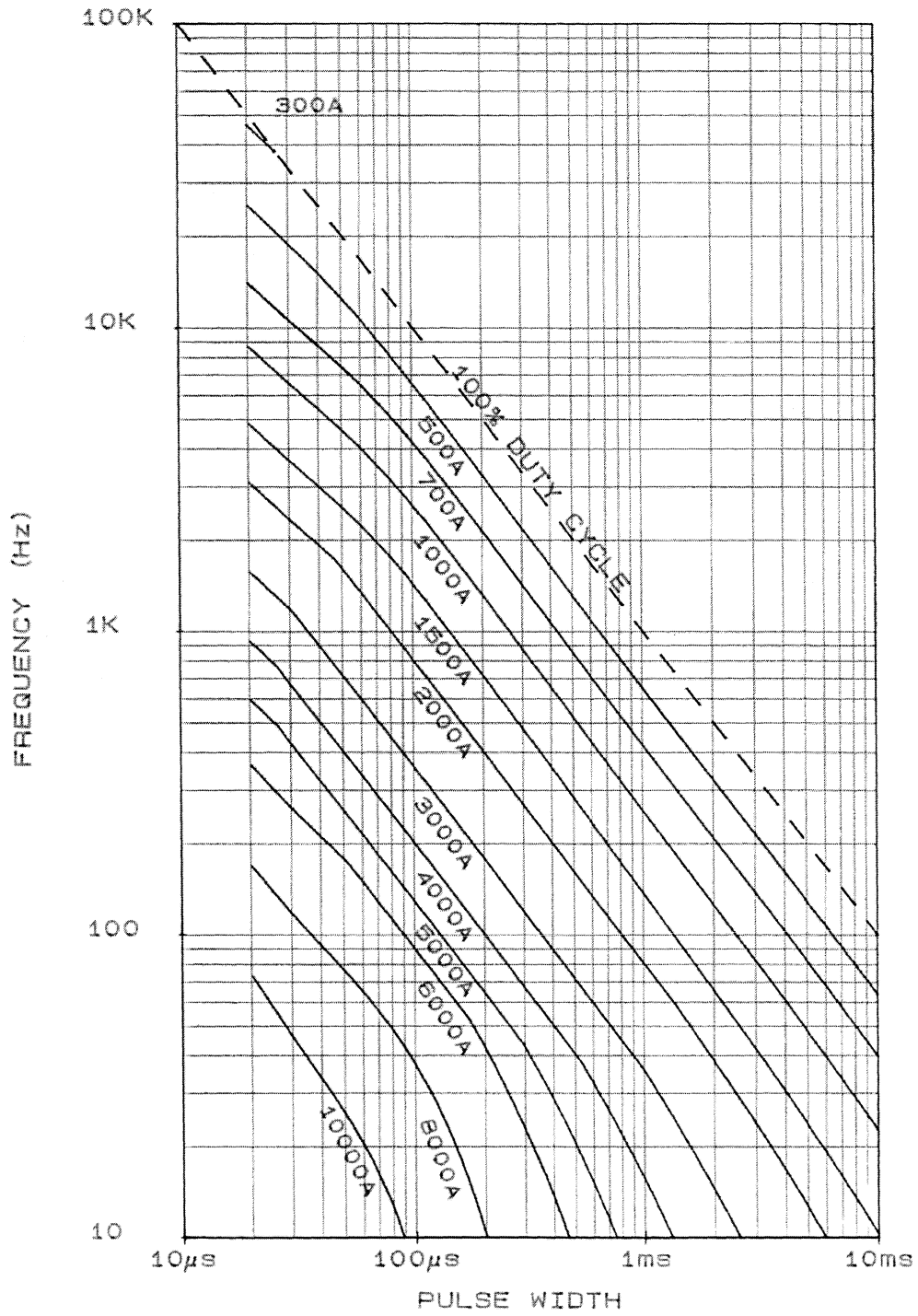

T CASE 60degC, SINEWAVE

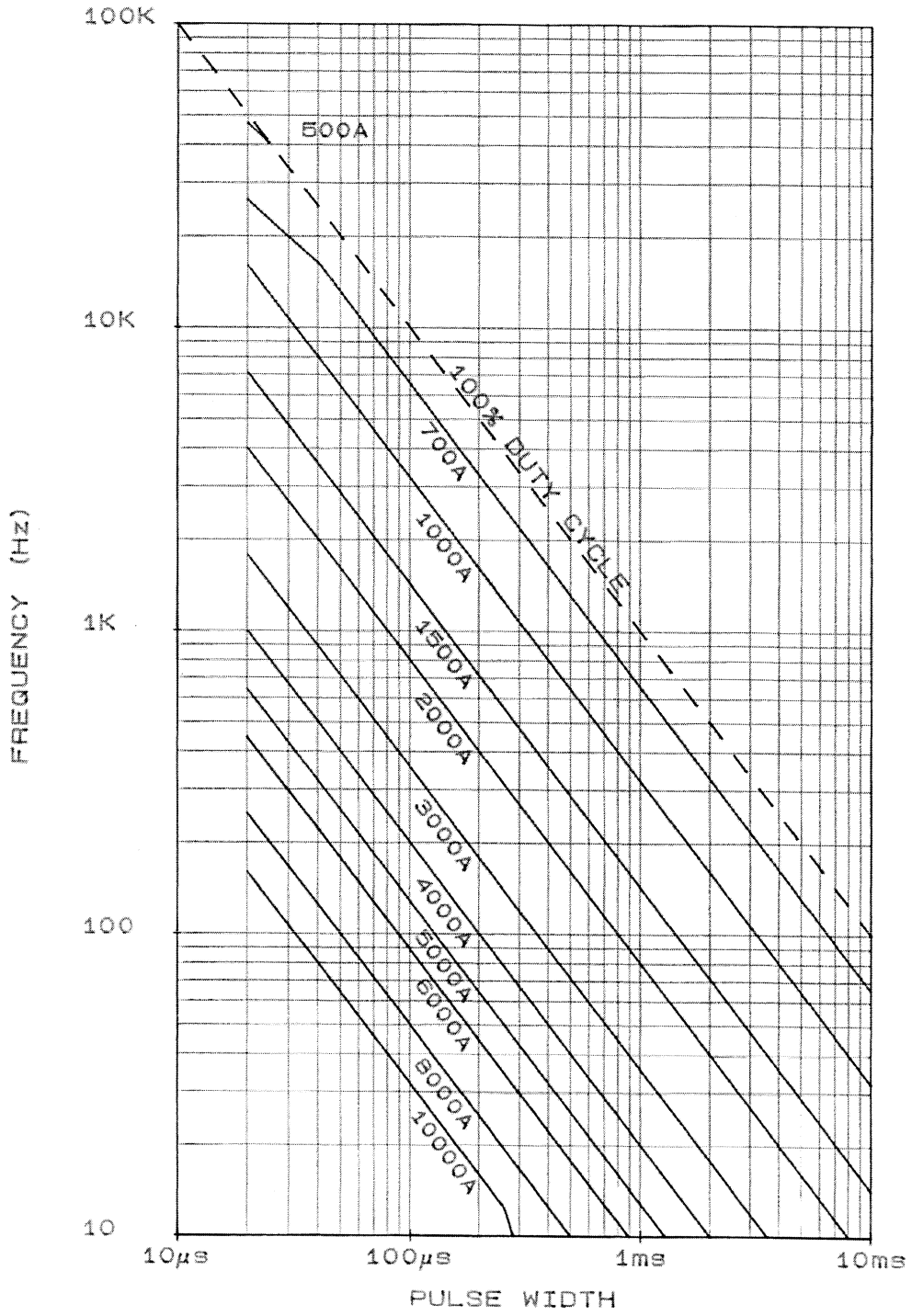

TJ 125°C. SINE WAVE

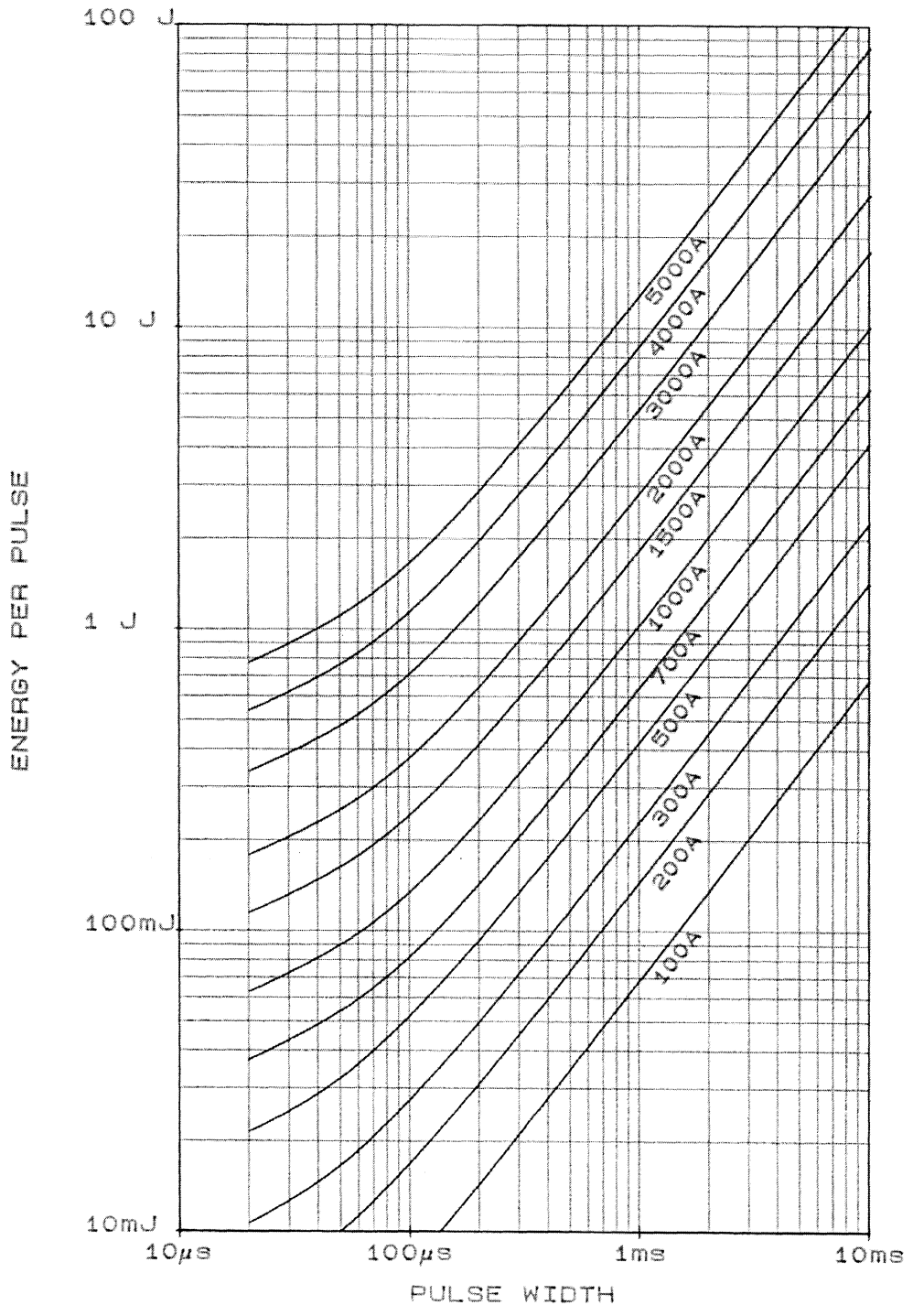

DRN	11
CHKD	11
APPD	
S	A
S	NI

INTERNATIONAL OUTLINE No. RR
 WEIGHT. 250 GRAMS.
 FINISH. BRIGHT NICKEL PLATE.
 DEVICE MARKING INCLUDES MONOGRAM, TYPE No., SPEC. No. AND POLARITY SYMBOL.
 DEVICE MOUNTING:
 MOUNTING TORQUE TO BE 27 - 24.5 Nm (2.77 - 2.5 kgf m).
 THREAD MUST NOT BE LUBRICATED.

DIODE TYPE NUMBER
 PHN/R 380
 PHN/R320
 PHN/R174

G.A. DRG. No. 102A216H04.

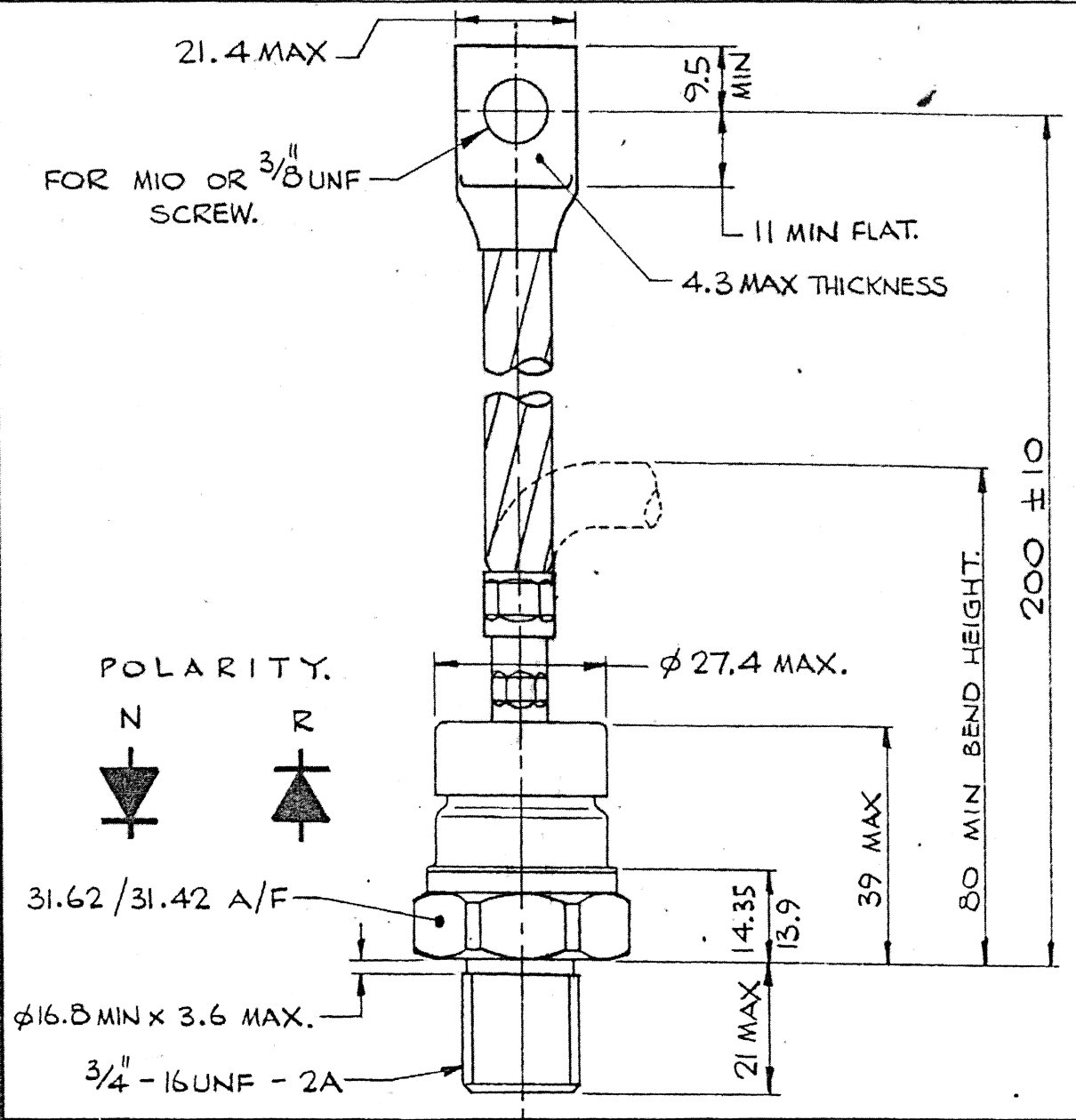

THE INFORMATION CONTAINED IN THIS DRAWING IS SUPPLIED IN CONFIDENCE AND IS PROTECTED BY COPYRIGHT. THE INFORMATION MAY NOT BE DISCLOSED EXCEPT WITH THE WRITTEN PERMISSION OF AND IN MANNER PERMITTED BY, THE PROPRIETORS, WESTINGHOUSE BRAKE AND SIGNAL CO. LTD.

WESTINGHOUSE BRAKE AND SIGNAL CO. LTD.
 CHIPPENHAM, WILTSHIRE, SN15 1JD, ENGLAND.

WESTCODE®
 SEMICONDUCTORS

THIRD ANGLE PROJECTION

 DIMNS. IN MILLIMETRES

DRG. No.
 100A280

REV	REVISIONS
1	11.9.75.
4	12.12.79 M306 REDRAWN. DRG. N ^o WAS 100A257.
5	27.11.84 M218 FIN WAS ET

Drawing Number – W22
Outline Number – 100A297

WESTCODE
An IXYS Company

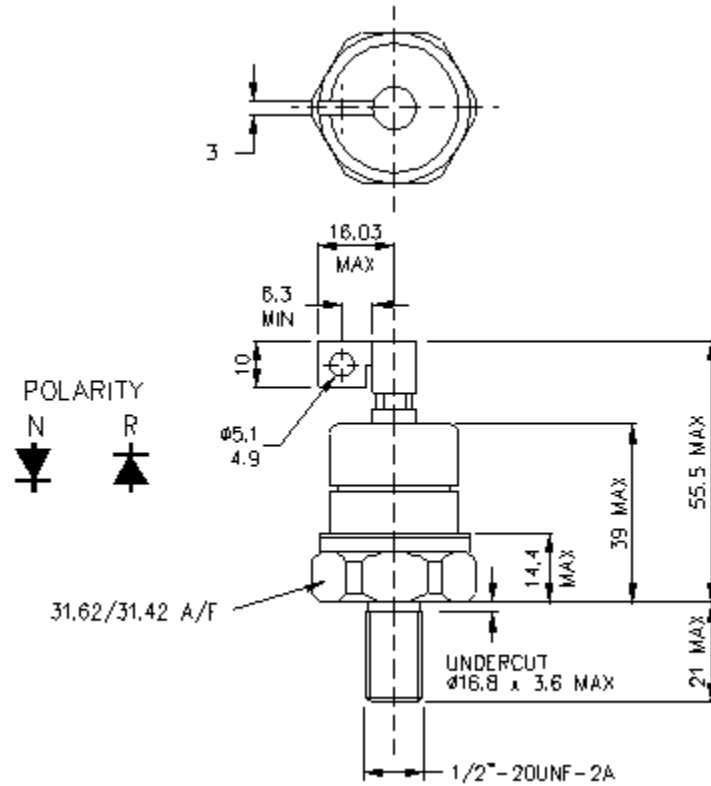

Weight 200g

Drawing Number – W24
Outline Number – 100A280

WESTCODE
An IXYS Company

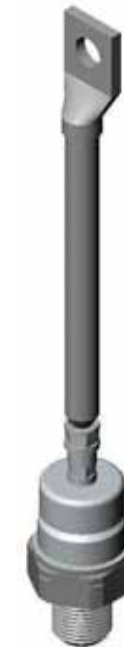
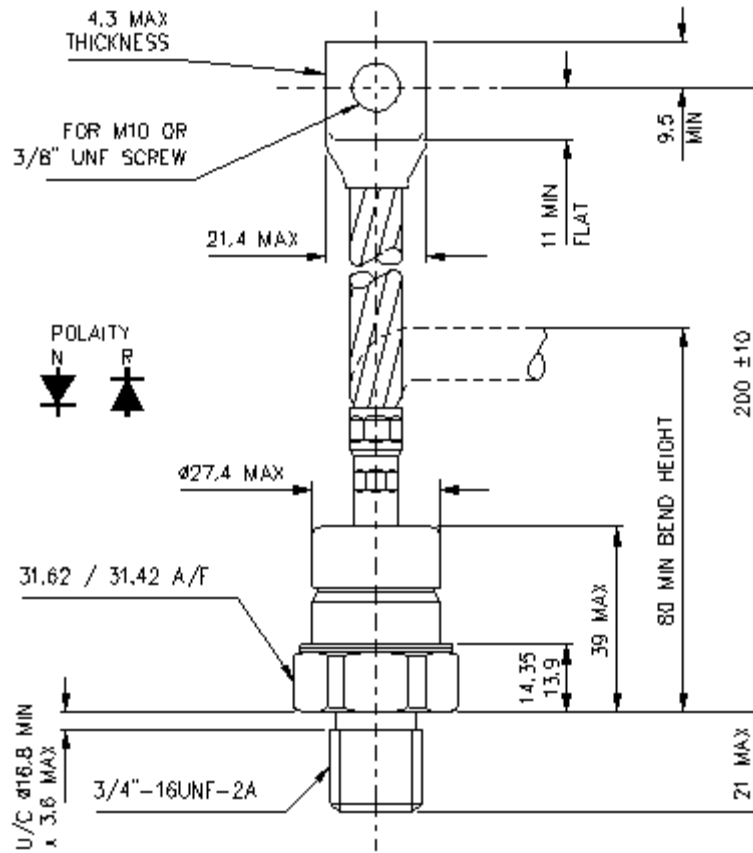

Weight 250g